

Fig.4 Control by optimisation of the available power

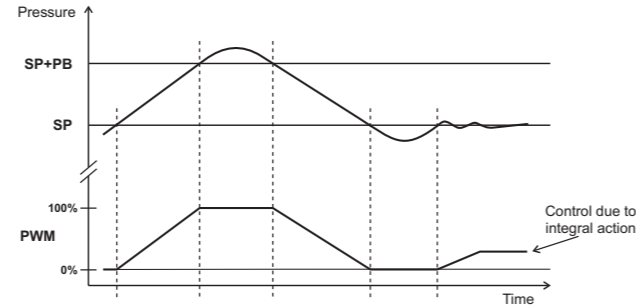
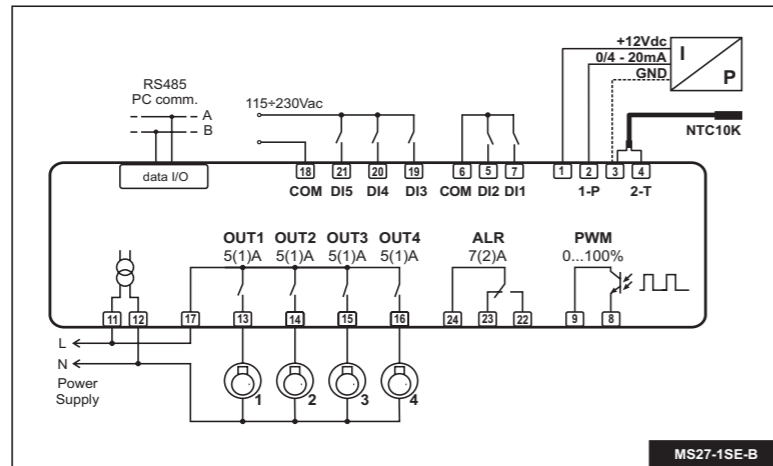

Fig.5 PWM output control

WIRING DIAGRAMS



TECHNICAL DATA

Power supply

MS27...E 230Vac±10%, 50/60Hz, 3W
MS27...U 115Vac±10%, 50/60Hz, 3W

Relay outputs

OUT1...OUT4 5(1)A
Alarm 7(2)A

Pressure input

type: 0/4...20mA
range: -1.0...45.0bar
resolution: 0.1bar

Temperature input

type: NTC10K (LAE SN4...)
range: -50.0...120.0°C
resolution: 0.5°C (-20.0...80.0); 1°C out of that range

Operating conditions

-10 ... +50°C; 15...80% r.H.

CE (Reference norms)

EN60730-1; EN60730-2-9;
EN55022 (Class B);
EN50082-1

Front Protection

IP55



lae
ELECTRONIC
VIA PADOVA, 25
31046 ODERZO /TV /ITALY
TEL. +39 - 0422 815320
FAX +39 - 0422 814073
www.lae-electronic.com
E-mail: sales@lae-electronic.com

MS27 INSTRUCTIONS FOR USE

Thank you for having chosen an LAE electronic product. Before installing the instrument, please read this instruction booklet carefully in order to ensure safe installation and optimum performance.

DESCRIPTION

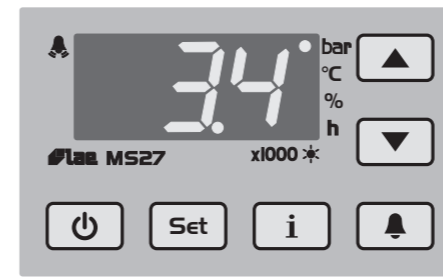

Fig.1 - Front Panel

INDICATIONS

- bar Pressure display in bar
- °C Temperature display in °C
- % Percentage of use of available power
- h Hours of operation (LED lit)
- x1000 Thousands of hours of operation (LED blinking)
- Alarm
- Stand-by button
- Setpoint button
- Info button
- Alarm display button
- Increase button
- Decrease button

INSTALLATION

- The controller, size 71x97x61 mm (WxHxD), is to be secured to a DIN rail in such a position as to ensure that no liquid infiltrates causing serious damage and compromising safety.
- Make sure that electrical connections comply with the paragraph "wiring diagrams". To reduce the effects of electromagnetic disturbance, keep the sensor and signal cables well separate from the power wires.
- Connect a pressure transmitter with output 0/4...20mA to input 1-P. Whenever control takes place through temperature, connect an NTC10K probe (part No. LAE SN4...) to input 2-T.

OPERATION

DISPLAY

Parameter INP selects the input used for control.

■ INP=1-P: Input 1-P (0/4...20mA) is used to control pressure. In the setup the parameters relating to the variable to be controlled (SPL, SPH, SP,...) are expressed in bar. In normal mode, the display shows the pressure measured in bar, or the corresponding temperature in °C, calculated according to the refrigerant gas used (see REF). Input 2-T is disabled.

■ INP=2-T: Input 2-T (NTC10K) is used for temperature control. In the setup the parameters relating to the variable to be controlled (SPL, SPH, SP,...) are expressed in °C. In normal mode the display shows the temperature measured in °C, or the corresponding pressure calculated in bar. Input 1-P is disabled.

In normal mode it's also possible to display the percentage of available power used. To modify the type of display, press ∇ or \blacktriangle .

The following indications may also appear:

OFF	Controller in stand-by	LL	Low refrigerant level alarm
or	Over range or probe failure	ALr	Generic alarm
hP	High pressure alarm	hi	High measured value alarm
LP	Low pressure alarm	Lo	Low measured value alarm
oil	Low compressor oil alarm	ntn	Periodic maintenance warning

INFO MENU

To have access to the info menu, press button \mathcal{I} . The available info is:

out...4	Output 1..4 state / hours of operation	ilo	Min input value measured.
hi	Max. input value measured.	loc	Keypad state (lock)

Access to menu and information displayed.

- With button ∇ or \blacktriangle select the data to be displayed;
- Press button \mathcal{I} to display the value;
- To exit from the menu, press button \mathcal{O} or wait for 10seconds

Reset of hours of operation of out1...out4 outputs and of IHI, ILO recordings

- With buttons ∇ or \blacktriangle select the data to be reset;
- Press button \mathcal{I} to display the value;
- While keeping button \mathcal{I} pressed, use button \mathcal{O} .

Display of hours of operation of out1...out4 outputs

- With button ∇ or \blacktriangle select the output;
- Display the ON/OFF state of output by pressing button \mathcal{I} ;
- While holding down button \mathcal{I} , press button \blacktriangle to display the hours of operation (multiplied by 1000); the "h" LED blinks.
- While holding down button \mathcal{I} , press button ∇ to display the hours of operation; the "h" LED is lit.
- Warning: the hours of operation of stages are not stored, '---' is displayed.

SETPOINT (display and modification of desired pressure/temperature value)

- Press button \mathcal{S} for at least half second, to display the setpoint value;
- If the second setpoint has been enabled (see DI1, DI2), before its value appears, the display shows "2SP";
- By keeping button \mathcal{S} pressed, use button ∇ or \blacktriangle to set the desired value (adjustment is within the minimum SPL and the maximum SPH limit).
- When button \mathcal{S} is released, the new value is stored.

ALARM MENU

The last nine alarms can be displayed in the alarm menu, from the most recent AL1, to the least recent AL9.

Access to menu and display of stored alarm.

- Press button \mathcal{A} ;
- With button ∇ or \blacktriangle select the data to be displayed;
- Press button \mathcal{A} to display the alarm type;
- To exit from the menu, press button \mathcal{O} or wait for 10 sec.

Reset of all stored alarm.

- Press button \mathcal{A} to display the type of any alarm in the list;
- By keeping button \mathcal{A} pressed, press button \mathcal{O} for 1 second, until the inscription 'non' appears.

STAND-BY

Button \mathcal{O} when pressed for 3 seconds, allows the controller to be put on a standby or output control to be resumed (with SB=YES only).

KEYPAD LOCK

The keypad lock avoids undesired, potentially dangerous operations, which might be attempted when the controller is operating in a public place. In the INFO menu, set parameter LOC=YES to inhibit all functions of the buttons. To resume normal operation of keypad, adjust setting so that LOC=NO.

CONTROL

OUTPUT CONFIGURATION

Outputs are configured with parameters **OC1, OC2, OC3, OC4**. Parameter **OCx** controls the operation of output OUTx: **OCx=1...100** indicates the power in percentage over the total power, of the compressor connected to OUTx. With **OCx=-1**, output OUTx is associated to a stage, which is active when the relay is closed. With **OCx=-2**, output OUTx is associated to a stage, which is active when the relay is open. With **OCx=0**, output OUTx is not used for control.

*Warning: the output associated to the compressor motor must always be wired in the terminals located before the terminals where the outputs controlling the stages are. Example: in a system with two compressors of different power (the first with 60% of total power, the second with 40%), each compressor having a stage, the configuration of outputs is as follows: **OC1 = 60, OUT1** is connected to the motor of compressor 1 of power equal to 60% of total power. **OC2 = -1, OUT2** is connected to the stage of compressor 1, the stage is active when the relay is closed. **OC3 = 40, OUT3** is connected to the motor of compressor 2 of power equal to 40% of total power. **OC4 = -1, OUT4** is connected to the stage of compressor 2.*

CONTROL ALGORITHM

Parameter CM provides the control algorithm.

- **CM=ROT**: rotation of outputs of equal power. This algorithm minimises the number of starts/stops per hour of each load. When the system calls for more power, the output which has been off for longer will be activated. When demand for power decreases, the output which has been on for longer will be switched off. When an output remains active for more than LRT minutes, the controller looks for an inactive output fulfilling the requirements to be activated (less hours of operation, minimum off time elapsed,...) and the rotation of the two outputs will take place. In this way, an equal sharing of the total operation time among all loads will be achieved (see Fig. 2). *Note: the compressor rotation algorithm assumes that compressors have got an equal power. In this case, parameter **OCx** is used only to define if output OUTx either controls a compressor or a stage. So, if the value is positive, it will have no effect on **OCx**, regardless of what you program. Example: in a system consisting of four compressors, each will have a power equal to 25% of the total value, regardless of the value programmed to **OCx**.*

- **CM=SEN**: sequential activation of the enabled outputs. The outputs are switched on/off with fixed sequence, from output 1 to output 4 (see Fig. 3).

- **CM=PO**: optimisation of the available power. The controller combines the outputs in such a way as to obtain a fine control, both in case of calls for more power and less power. Example: **OC1=10, OC2=20, OC3=30, OC4=50**. If a capacity of 90 is required, outputs OUT1, OUT3, OUT4 (10+30+50) are switched on. If a capacity of 50 is required, outputs OUT2 and OUT3 (20+30) are switched on (see Fig. 4).

CONFIGURATION PARAMETERS

- To get access to the parameter configuration menu, press button **[Set]** + **[0]** for 5 seconds;
- with button **[V]** or **[A]** select the parameter to be modified;
- press button **[Set]** to display the value;
- by keeping button **[Set]** pressed, use button **[V]** or **[A]** to set the desired value;
- when button **[Set]** is released, the newly programmed value is stored and the following parameter is displayed;
- to exit from the setup, press button **[0]** or wait for 30 seconds.

Note: re-programming some parameters causes a complete re-configuration of the controller operation. So please put the controller on stand-by, if you have to modify the parameters relating to the output configuration or the selection of the control algorithm.

(In the parameter description, we refer to 'pressure control'. In case of temperature based control, please replace the word 'pressure' with 'temperature' and 'bar' with '°C').

PAR	RANGE	DESCRIPTION
INP	1-P, 2-T	Input selection for control 1-P : input 1-P is used for pressure control; input 2-T is disabled. 2-T : input 2-T is used for temperature control; input 1-P is disabled.
INP=1-P	MPI	0mA, 4mA Min. current input range. 0mA : input 0...20mA; 4mA : input 4...20mA
	RLO	-1.0...RHI bar Min. scale range. RLO takes the minimum value measured by the transmitter (corresponding to 0/4mA).
	RHI	RLO...45.0bar Max. scale range. RHI takes the maximum value measured by the transmitter (corresponding to 20mA).
OS1	-12.0...12.0bar	Probe offset
REF	404,507,22,134	Refrigerant used. It allows Pressure - Temperature conversion. 404 =R404A, 507 =R507, 22 =R22, 134 =R134A
SPL	RLO...SPH	Minimum limit for SP and 2SP setting
SPH	SPL...RHI	Maximum limit for SP and 2SP setting
SP	SPL...SPH	Main setpoint, indicates the pressure to be maintained.
2SP	SPL...SPH	Alternate Setpoint. Pressure reference point is 2SP if DI1 (DI2) = 2SP and the corresponding input is active.
DBL	-10.0...0.0bar	Lower neutral zone.
DBH	0.0...10.0bar	Higher neutral zone.
The state of outputs remains unchanged as long as pressure is within the band SP+DBL and SP+DBH.		
LON	0...250s	Load start delay. Pressure must remain higher than SP+DBH for LON seconds before the next load is switched on.
LOF	0...250s	Load stop delay. Pressure must remain lower than SP+DBL for LOF seconds before the next load is switched off.
SON	0...250s	Stage start delay. Pressure must remain higher than SP+DBH for SON seconds before the next stage is switched on.
SOF	0...250s	Stage stop delay. Pressure must remain lower than SP+DBL for SOF seconds before the next stage is switched off.
PB	0...20.0bar	Proportional band (PWM output control, see Fig. 5). Zone above setpoint in which the PWM output is activated proportionally. <i>Example: pressure < SP, PWM=0%; pressure=SP+PB/2, PWM=50%; pressure>SP+PB, PWM=100%.</i>
IT	0...250s	Integral action time (control of PWM output, see Fig. 5). The greater the IT value, a more stable control takes place.
CM	ROT, SEN, PO	Selection of control algorithm. ROT : rotation of equal power outputs. SEN : sequential activation of outputs. PO : optimisation of available power.

OC1, OC2, OC3, OC4	-2...100	Control of output 1, 2, 3, 4. 1...100 : power (percentage of total) of the load connected to output OUTx (x=1, 2, 3, 4); 0 : output OUTx not used; -1 : output OUTx connected to a stage, which is activated when the contact is closed. -2 : output OUTx connected to a stage, which is activated when the contact is open.
MLS	0...30min	Minimum off time of loads. Minimum time which must elapse between when the load is switched off and when it's switched on again.
LRT	0...120min	Time of forced rotation of loads (only with CM=ROT). This parameter, if greater than 0, provides the operation time of a load after which the controller takes into account the possibility of rotation of two outputs.
DPU	0...120min	Start delay. Delay between the time when the controller is switched on when the outputs are activated, in order for the compressor crankcases to warm up.
SCD	0...100 %	Down Scaling. It indicates the maximum per cent power usable during an alarm with enabled down scaling action.
ALA	RLO...AHA	Low value measured alarm threshold.
AHA	ALA...RHI	High value measured alarm threshold.
AID	0...120min	High/Low alarm delay.
D1M D2M	NON, SBY, 2SP, ALR	Function of digital input DI1, DI2. NON : input disabled; SBY : when input DI1 (DI2) is active, the controller is put on a stand-by. 2SP : when input DI1 (DI2) is active, the control setpoint is 2SP. ALR : when input DI1 (DI2) is active, the controller detects a generic alarm which causes the display to show ALR, to load to be switched off and control to be stopped. When the alarm is over, the controller resumes output control automatically (automatic reset).
D1C D2C	OPN, CLS	Activation of digital input DI1, DI2. OPN : active input is open; CLS : active input is closed
DxM	NON,HP, LP, OIL, LL, ALR	Function of digital input DI3, DI4, DI5. NON : input disabled. HP : high pressure alarm. LP : low pressure alarm. OIL : low compressor oil level. LL : low refrigerant level alarm. ALR : generic alarm.
DxC	OPN, CLS	Activation of digital input DI3, DI4, DI5 (see D1C).
DxD	0...120min	Activation delay of alarm DI3, DI4, DI5. The digital input must remain in the activation condition for this time before the alarm is detected.
DxA	DSP, SAR, SMR	Reaction following alarm DI3, DI4, DI5. DSP : alarm display. SAR : in addition to the alarm displayed, a down scaling (SCD) is activated and control is stopped. When the alarm is over, the controller resumes output control automatically (automatic reset). SMR : in addition to alarm displayed, all loads are switched off and control is stopped. When the alarm is over, control is resumed but only after the alarm has been acknowledged by pressing button [M] (manual reset).
MTC	0...600 (x100hours)	Maintenance. When the operation hours of any load achieve this value, a maintenance warning will flash on display. To eliminate this warning, after performing maintenance, rest the hour counters as described in paragraph "info menu".
SB	NO/YES	Stand-by button enabling.
TLD	1...30min	Delay for min / max input loggin.
SND	NO/YES	Alarm buzzer enabling
ADR	1...255	MS27 address for PC communication.

OPERATION EXAMPLES

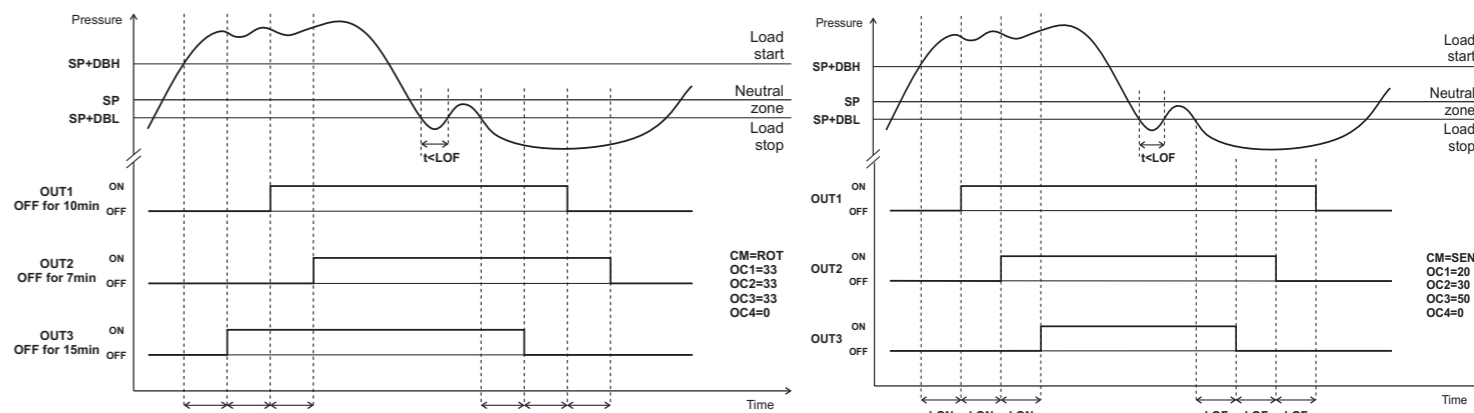

Fig.2 Control by rotation of outputs of equal power

Fig.3 Control by sequential activation of outputs