

## Refrigeration Controllers with Defrost

# LCD32

196x38x78 mm



## Compact multi-function defrost unit

### Main Features

- Panel thermostat for High and Low Temperature
- Output to control the compressor directly
- Evaporator fan control
- Electrical, hot gas or off cycle defrost
- Light or auxiliary load control
- Quick connectors for Lives and Neutrals
- Two operating parameter sets
- HACCP functions
- Door open, high/low temperature, HP alarms
- Automatic condenser clean warning
- Quick setup through ZOT-LCD device
- Connection to LAE supervisory system TAB
- Runs on mains power supply.

### Applications

Cold stores, refrigerating cabinets, tables and counters, saladettes, medical cabinets and display cases, both static and ventilated.

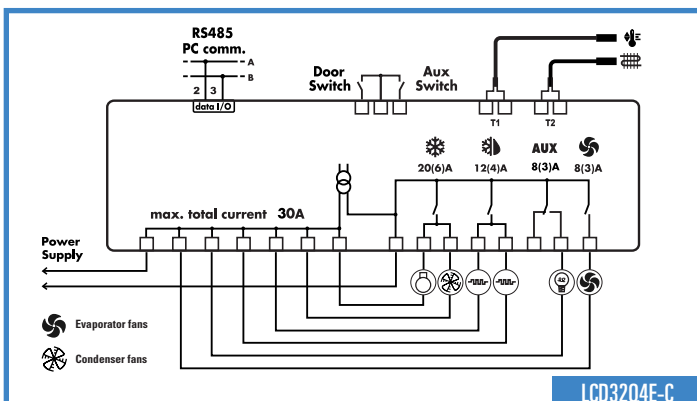

### LCD32 Series

Functions		Q3E	S3E	Q3E-A	S3E-A	Q4E-C	S4E-C
Connections		Quick	Screw	Quick	Screw	Quick	Screw
Inputs	thermostat	✓	✓	✓	✓	✓	✓
	evaporator	✓	✓	✓	✓	✓	✓
Outputs	thermostat	✓	✓	✓	✓	✓	✓
	defrost	✓	✓	✓	✓	✓	✓
	evaporator fans	✓	✓	✓	✓	✓	✓
	auxiliary					✓	✓
Options	door+Aux switch			✓	✓	✓	✓
	TTL serial port	✓	✓	✓	✓		
	RS485 serial					✓	✓
Supply#	230Vac	✓	✓	✓	✓	✓	✓

# Versions with 110Vac supply are also available.

\* On request the LCD32 is also available with gasket for a better protection between bezel and metal panel.

In this case, the code changes in, for ex. LCD32Q4E-CS. Please ask information about standard versions available with this option.

In order to know versions available, please consult LAE or our local dealer.

### Technical Data

<b>Programming Range:</b>	-30.0÷30.0°C
<b>Resolution:</b>	0.1 / 1; °C / °F
<b>Accuracy:</b>	<±0.2°C (-30.0÷30.0°C)
<b>Sensor type:</b>	NTC, standard mod. SN2K20P1/P2
<b>Power supply:</b>	230Vac ±10%; 50/60Hz; 3W
<b>Front protection:</b>	IP55
<b>Panel cut-out:</b>	163x31.5 mm
<b>Ambient temperature:</b>	-10 ÷ 50°C